

NEW LOWER COST NORWECO'S WASTEWATER TREATMENT PLANT... THE SINGULAIR® DIRECT BURY UV NPDES SYSTEM

REDUCTION IN BOD₅ / TSS THAT EXCEEDS 98% WITH
ULTRAVIOLET DISINFECTION AND POST AERATION

PERFORMANCE THAT PROTECTS THE ENVIRONMENT!

The Singulair® Direct Bury UV NPDES system has been approved for EPA General NPDES Permit applications and is perfect for sites where effluent disposal options are limited.

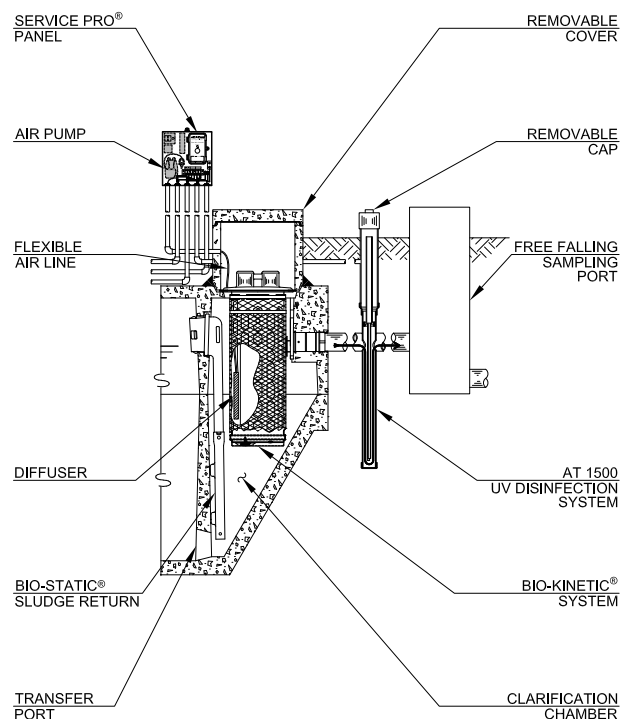
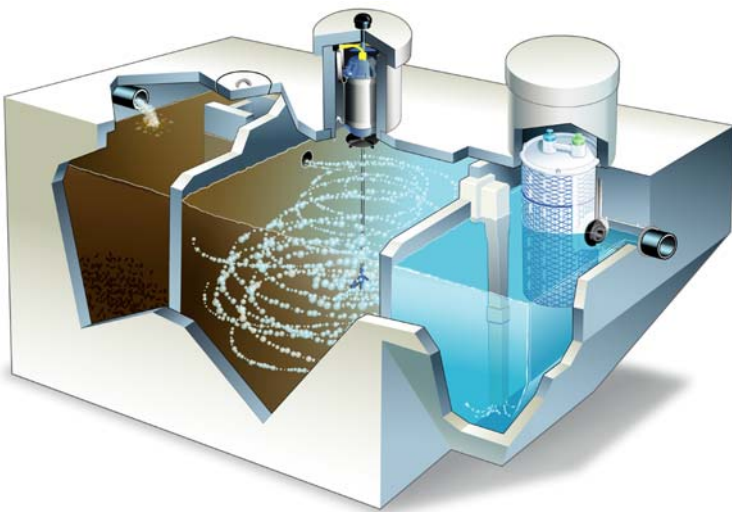

Seamlessly integrating several proven technologies, the Singulair® Direct Bury UV NPDES system's primary treatment platform is the Model 960 equipped with Service Pro® remote monitoring. The UL Listed Service Pro® control center automatically notifies service providers if a component alarm is detected.

Also included in this NPDES system is an AT 1500 UV disinfection system and post aeration. All components in the NEMA 4X rated equipment enclosure are pre-wired for ease of installation.



SINGULAIR® NPDES FEATURES

- Precast concrete tank
- Low maintenance
- Flow equalization
- Post aeration
- Low electrical usage
- UV disinfection
- Lifetime aerator warranty and exchange
- Sold and serviced by local distributors

norweco®

*Engineering the future of water
and wastewater treatment*

220 REPUBLIC STREET
NORWALK, OHIO, USA 44857-1156
TELEPHONE (419) 668-4471
FAX (419) 663-5440
www.norweco.com